

InterReach Unison®

In-Building Wireless Networking System



As its name suggests, InterReach Unison operates as a seamless extension of the public wireless network infrastructure, expanding the reach of wireless communications by delivering crystal-clear signals and ample capacity throughout any public or private facility.

This solution provides a revolutionary degree of flexibility, power and intelligence that accommodates unique requirements elegantly; adapts to changing needs easily; and keeps system life-cycle costs low. Simply stated, InterReach Unison is the only intelligent software-based wireless networking system to meet today's demand and provide the power and flexibility to adapt to tomorrow. InterReach Unison was created specifically to address the needs of larger installations and dense, high-traffic environments, such as convention centers, sporting venues and airports. The system has a modular architecture and uses industry-standard, lightweight cables.

In addition, it:

- Delivers superior radio frequency performance and high composite power thereby supporting more channels and delivering greater coverage while operating as an integral part of the broader wireless network
- Has software configurable components for flexible system configuration
- Offers simple installation using minimal components
- Uses only industry-standard cabling and provides a choice of cabling types
- Includes the most advanced operations, administration, and maintenance features in the industry

PRODUCT HIGHLIGHTS





InterReach Unison®

In-Building Wireless Networking System

4 / 0 8 • 1 0 6 0 1 9 A E InterReach Unison®

InterReach Unison Features

- Delivers wireless voice and data
- Compatible with all major access protocols used worldwide including GPRS, EDGE, CDMA2000, 1xRTT and W-CDMA.
- Superior RF performance and high composite power supports more channels and delivers the ability to cover large areas with a minimal amount of equipment
- Software-selectable frequency configuration, system gain and RAU output power
- Offers industry-standard cabling options: either multi-mode or single-mode fiber optic cable and either CAT-5 or CAT-6 twisted pair wiring
- Modular and scalable double-star topology
- Can be deployed in the most difficult RF environments
- Easy to install without disrupting operations or décor
- Does not require separate power to the antennas
- Intelligent, software-controlled operations, administration and maintenance functions support both on-site and remote configuration and monitoring capabilities and give notice of hardware and cabling faults
- FCC, UL and CE Mark approved

Together, these unique features combine to provide wireless operators and building owners with power and intelligence in a single, versatile solution. No dropped calls. No static. No dead zones. Just clear signals when and where you want them.

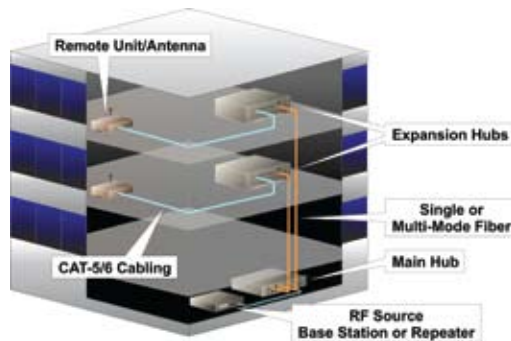



InterReach Unison®

In-Building Wireless Networking System

Components

InterReach Unison features an easy-to-deploy double-star architecture with just three components: a Main Hub, an Expansion Hub, and a Remote Access Unit (RAU) that connect using single- or multi-mode fiber and CAT-5/6 twisted-pair cabling. InterReach Unison's Main Hub, which can be connected to a base station, a MetroReach® Focus system, or a repeater, converts the incoming radio frequency signal to an optical signal and sends it to the Expansion Hub via fiber optic cable. The Expansion Hub converts the incoming optical signal to an electrical signal and distributes it to all associated RAUs via twisted pair cabling. The RAU converts the signal to RF once again and sends and receives those signals to wireless devices located within its coverage area.

The system's modular components are arrayed in a double-star topology with:

- 19" rack-mountable Main Hub
- 19" rack-mountable Expansion Hub
- Remote Access Unit (RAU)

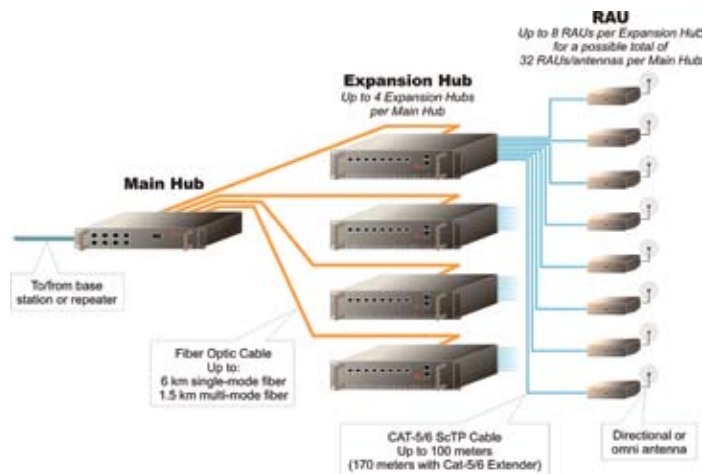

Each Main Hub supports up to four Expansion Hubs connected via single- or multi-mode fiber. Each of these Expansion Hubs can support up to eight RAUs connected by standard twisted-pair (CAT-5 or CAT-6) wire. Each RAU connects to an indoor antenna suited to the facility. Thus, each Main Hub can support up to 32 antennas. Multiple systems can be connected together to cover larger areas.

Protocols

InterReach Unison provides software-controlled configuration to support the following frequency bands:

Frequencies	Voice and Data Protocols
800 MHz	iDEN, SMR
850 MHz	AMPS, CDMA2000, TDMA, W-CDMA, GSM, EDGE
900 MHz	GSM, Paging, EDGE, iDEN, SMR
1800 MHz	GSM, CDMA2000, EDGE
1900 MHz	CDMA2000, GSM, TDMA, W-CDMA, EDGE
2100 MHz	W-CDMA
2100 MHz-AWS	W-CDMA

The system is compliant with key data standards such as GPRS/EDGE, and CDMA2000 1xRTT and has FCC, UL, and CE approvals. The Remote Access Units are plenum-rated.

4/08 • 106019AE InterReach Unison®

Ease of Installation

The ability to choose between various industry-standard cabling options provides additional flexibility during the system design phase and allows designers to select the cabling types that are best suited to a particular facility. This often means that the existing cabling infrastructure can be used, greatly reducing installation time, effort and cost. Only lightweight, industry-standard cables, which are cheaper to purchase and install than coaxial cable, are used. Finally, because power for the Remote Access Units is provided over the twisted-pair cabling, no local power is required, further simplifying installation.

When changes are needed - in either coverage area or system capacity - InterReach Unison adapts readily. When a new area needs to be covered, additional RAUs can be easily added to the 8-port Expansion Hub. Since the fiber runs can be up to 6 km and the twisted-pair cabling can reach as far as 170 meters, even nearby structures can be covered with minimal effort and equipment. Because channels may be added without the cost or effort of splitting cells, system capacity can be increased simply by allocating additional channels.

Unison's architecture has an additional advantage in that it mirrors that of a standard 802.11 system. Consequently, substantial installation cost savings can be gained by pulling Cat-5 cabling for both systems and installing the RAUs and 802.11 access points at the same time.

Management Tools

The InterReach Unison and Unison Accel in-building wireless systems provide coverage in thousands of locations around the world. But ADC realizes that after the installation, sophisticated systems management is critical for providing continuous wireless service. To meet these requirements, ADC provides a comprehensive and flexible set of system management solutions and services.

ADC provides its GUI-based AdminManager software tool for quickly configuring the system. With features like automated system calibration and warnings on excessive cable length, Unison and Unison Accel have the intelligence to help ensure peak performance from the start.

The AdminManager tool can be used for both on-site and remote management of the system. In addition, ADC's Network Interface Unit (NIU) provides SNMP support for monitoring and maintaining one or more remote Unison systems via a standard SNMP network management system. The NIU converts Unison status, warning and fault messages to SNMP traps that are forwarded to the customer-supplied centralized NMS system.

- ADC's Unison and Unison Accel systems continuously monitor over 60 parameters, in its system components. Should a fault condition develop, Unison proactively sends notification via one of several methods:
- Alarm contacts connected to a basestation that is monitored by the wireless operator's network management system
- Modem outcalling to a cellular phone or pager
- SNMP traps to an SNMP Network Management System (NMS)



Website: www.adc.com

From North America, Call Toll Free: 1-800-366-3891 • Outside of North America: +1-952-938-8080

Fax: +1-952-917-3237 • For a listing of ADC's global sales office locations, please refer to our website.

ADC Telecommunications, Inc., P.O. Box 1101, Minneapolis, Minnesota USA 55440-1101

Specifications published here are current as of the date of publication of this document. Because we are continuously improving our products, ADC reserves the right to change specifications without prior notice. At any time, you may verify product specifications by contacting our headquarters office in Minneapolis. ADC Telecommunications, Inc. views its patent portfolio as an important corporate asset and vigorously enforces its patents. Products or features contained herein may be covered by one or more U.S. or foreign patents. An Equal Opportunity Employer

106019AE 4/08 Revision © 2008 ADC Telecommunications, Inc. All Rights Reserved