

InterReach Unison Accel®



InterReach Unison Accel offers the same superior performance and administrative capability as Unison in an easy-to-install and economical package. It is ideal for small to mid-sized structures such as office buildings, regional distribution facilities, small conference centers, and healthcare clinics.

PRODUCT HIGHLIGHTS

InterReach Unison Accel Features:

- Delivers wireless voice and data throughout small to medium sized facilities
- Compatible with all major access protocols used worldwide including GPRS, EDGE, CDMA2000, and W-CDMA
- Superior RF performance and high composite power supports more channels and delivers the ability to cover areas with a minimal amount of equipment
- Software-selectable frequency configuration, system gain and RAU output power
- Offers industry-standard cabling options: either CAT-5 or CAT-6 twisted pair wiring
- Modular and scalable hub and spoke topology
- Easy to install without disrupting operations or décor
- The RAUs are line-powered from the hub, alleviating the need for separate power to the antennas
- Intelligent, software-controlled operations, administration and maintenance functions support both on-site and remote configuration. Additionally, SNMP traps can be generated using optional third-party equipment
- FCC, UL and CE Mark approved





InterReach Unison Accel®

InterReach Unison Accel offers the following benefits:

- Superior in-building wireless coverage and capacity. Accel is able to provide this because of two reasons.
 - First, the system provides high composite output power for a strong signal to the mobile device, thus providing a wide coverage area and supporting more channels for higher capacity usage by many users and/or data applications.
 - Secondly, Accel's design clearly receives the "uplink" signal from mobile devices being used in the building, allowing the devices to operate at lower power levels than if they were communicating directly through the walls to the outdoor network. Lower power levels mean that batteries last longer and the handsets stay cooler.
- Simple hardware installation using standard Cat-5/Cat-6 cabling for connecting the hub to the Remote Access Units (RAUs)
- Quick system configuration because of software configurable components
- Industry leading administration and maintenance capabilities
- Flexible adaptability to new protocols and standards as they emerge

In addition, Accel's design mirrors that of a standard 802.11 system. Because each system uses standard, lightweight Cat-5 cabling, it is easy to install both at the same time for substantial savings on the overall installation cost.

Altogether, Accel's powerful combination of benefits come together to seamlessly allow mobile users to communicate and transact business. No dropped calls. No static. No dead zones. Just clear signals when and where you want them.

Components

InterReach Unison Accel features an easy-to-deploy hub and spoke architecture with just two types of components: a Hub that connects via CAT-5 to up to eight Remote Access Units (RAUs). The Accel Hub receives its radio frequency (RF) signal from a base station, a MetroReach Focus system, or a repeater. The Hub electrically distributes the signal to the RAUs via twisted pair cabling. Each RAU converts the signal to RF and sends — and receives — the signals via antennas connected to the RAU to the wireless phones and PDAs located within its coverage area.

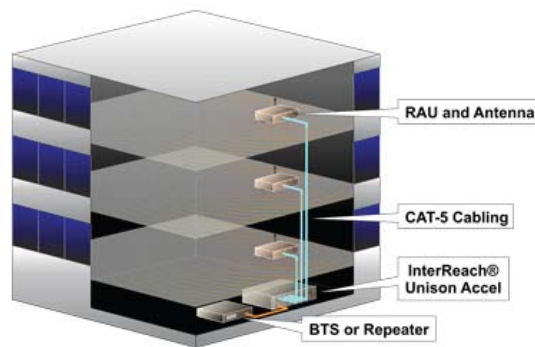



InterReach Unison Accel®

The Accel hub is packaged in a 19" rack-mountable unit. The small RAUs, and the antennas connected to them, are typically mounted in ceiling spaces throughout the facility. The CAT-5 cabling between the hub and each of the eight RAUs can be up to 100 meters (328 feet) long. This length can be extended to 170 meters (557 feet) with the optional Cat-5 Extender. By using Cat-5 Extenders, the "wingspan" from one RAU through the hub to an RAU on the other side of the facility can be up to 340 meters (1,114 feet).

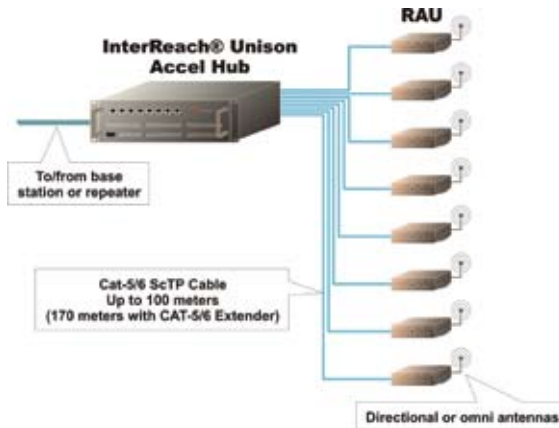

Protocols

InterReach Unison Accel provides software-controlled configuration to support the following frequency bands:

Frequencies	Voice and Data Protocols
800 MHz	iDEN, SMR
850 MHz	AMPS, CDMA2000, TDMA, W-CDMA, GSM, EDGE
900 MHz	GSM, Paging, EDGE, iDEN, SMR
1800 MHz	GSM, CDMA2000, EDGE
1900 MHz	CDMA2000, GSM, TDMA, W-CDMA, EDGE
2100 MHz	W-CDMA
2100 MHz-AWS	W-CDMA

The system is compliant with key data standards such as GPRS/EDGE, and CDMA2000 1xRTT and has FCC, UL, and CE approvals. The Remote Access Units are plenum-rated.

Ease of Installation

The ability to choose between various industry-standard cabling options provides additional flexibility during the system design phase and allows designers to select the cabling types that are best suited to a particular facility. This often means that the existing cabling infrastructure can be used, greatly reducing installation time, effort and cost. Only lightweight, industry-standard cables, which are cheaper to purchase and install than coaxial cable, are used. Finally, because power for the Remote Access Units is provided over the twisted-pair cabling, no local power is required, further simplifying installation.

When changes are needed - in either coverage area or system capacity - Unison Accel adapts readily. When a new area needs to be covered, additional RAUs can be easily added to the 8-port Hub. Because channels may be added without the cost or effort of splitting cells, system capacity can be increased simply by allocating additional channels to the system.

4 / 0 8 • 1 0 6 0 9 0 A E InterReach Unison Accel®

Management Tools

The InterReach Unison and Unison Accel in-building wireless systems provide coverage in thousands of locations around the world. But ADC realizes that after the installation, sophisticated systems management is critical for providing continuous wireless service. To meet these requirements, ADC provides a comprehensive and flexible set of system management solutions and services.

ADC provides its GUI-based AdminManager software tool for quickly configuring the system. With features like automated system calibration and warnings on excessive cable length, Unison and Unison Accel have the intelligence to help ensure peak performance from the start.

The AdminManager tool can be used for both on-site and remote management of the system. In addition, ADC's Network Interface Unit (NIU) provides SNMP support for monitoring and maintaining one or more remote Unison systems via a standard SNMP network management system. The NIU converts Unison status, warning and fault messages to SNMP traps that are forwarded to the customer-supplied centralized NMS system.

- ADC's Unison and Unison Accel systems continuously monitor over 60 parameters, in its system components. Should a fault condition develop, Unison proactively sends notification via one of several methods:
- Alarm contacts connected to a basestation that is monitored by the wireless operator's network management system
- Modem outcalling to a cellular phone or pager
- SNMP traps to an SNMP Network Management System (NMS)



Website: www.adc.com

From North America, Call Toll Free: 1-800-366-3891 • Outside of North America: +1-952-938-8080
 Fax: +1-952-917-3237 • For a listing of ADC's global sales office locations, please refer to our website.

ADC Telecommunications, Inc., P.O. Box 1101, Minneapolis, Minnesota USA 55440-1101
 Specifications published here are current as of the date of publication of this document. Because we are continuously improving our products, ADC reserves the right to change specifications without prior notice. At any time, you may verify product specifications by contacting our headquarters office in Minneapolis. ADC Telecommunications, Inc. views its patent portfolio as an important corporate asset and vigorously enforces its patents. Products or features contained herein may be covered by one or more U.S. or foreign patents. An Equal Opportunity Employer